

TABLE OF CONTENTS

1.0	INTRODUCTION	3
2.0	SPECIFICATIONS	4
2.1	CURRENT:	4
2.2	VOLTAGE:	4
2.3	MODES:	4
2.4	VOLTAGE CONTROL:	4
2.5	METERS:	4
2.6	STATUS INDICATORS:	4
2.7	CONTROLS:	4
2.8	TIMER:	4
2.9	FUSES:	5
2.10	LINE VOLTAGE:	5
2.11	LINE CURRENT:	5
2.12	AMBIENT:	5
3.0	DESCRIPTION	6
4.0	OPERATING INSTRUCTIONS	8
4.1	CHARGE:	8
4.1.1	Mode:	8
4.1.2	Time:	8
4.1.3	Voltage:	8
4.1.4	Connection:	8
4.1.5	Run:	8
4.1.6	Top:	8
4.2	DISCHARGE:	9
4.2.1	Mode:	9
4.2.2	Time:	9
4.2.3	Voltage:	9
4.2.4	Connection:	9
4.2.5	Run:	9
4.2.6	Stop:	9
5.0	BATTERY TESTING NOTES	10
6.0	VERIFICATION OF PERFORMANCE AND CALIBRATION	11
6.1	METERS BOARD	11
6.1.1	VOLTMETER:	11
6.1.2	AMMETER:	11
6.2	CONTROL CIRCUIT BOARD	13
6.2.1	R30 and R16, ZERO:	13
6.2.2	R31, MAX CURRENT:	13
6.2.3	R44, VOLTAGE:	13
6.2.4	TIMER:	14
6.2.5	CHARGE and DISCHARGE CURRENT:	16
7.0	TROUBLESHOOTING	17
7.1	DOES NOT TURN ON:	17
7.2	DOES NOT CHARGE or DISCHARGE:	17
7.3	DOES NOT CHARGE IN THE CONSTANT VOLTAGE MODE:	17
7.4	GOES INTO CYCLE END IMMEDIATELY IN THE PEAK CHARGE MODE:	17
7.5	FAULT ALARM:	17
7.6	CAPACITY FAILURE ALARM:	17
7.7	GOES INTO CYCLE END IMMEDIATELY IN ANY MODE:	17
7.8	DOES NOT RESPOND TO A CHANGE IN THE TIME SELECTOR:	17
8.0	INSTALLATION	18
8.1	SPACE:	18

8.2 LINE VOLTAGE:18
9.0 WIRING DIAGRAM 19
10.0 REVISION INDEX 20

TABLE OF FIGURES

Figure 1 - Front Panel7
Figure 2 - Rear Panel7
Figure 3 - Meters Board Adjustments.....12
Figure 4 - Control Board Adjustments15

1.0 INTRODUCTION

The BCA-1210 is an instrument designed to charge, trickle charge and analyze (discharge) Nickel-Cadmium, Sealed Lead-Acid and other types of rechargeable batteries.

With its multiple modes of operation of Constant Current Charge, Constant Current & Float Charge, Constant Current & Peak Stop Charge, Automatic Discharge (analysis) and Full Discharge (deep cycle), the BCA-1210 can satisfy the requirements of most small (0 to 10 A-hr) rechargeable battery systems.

The charger is basically a precision voltage controlled constant current source/sink with programmable current and voltage end points. It also features safety interlocks to protect the operator, the charger and the battery in the event of reversed polarity connection, short circuit, open circuit (no load) and overvoltage conditions.

Two large LED digital meters permit the simultaneous monitoring of voltage and current, while five indicator lights inform of the status of the operation.

An integral electronic timer complements the BCA-1210 charge and discharge operations in applications requiring a time limit.

2.0 SPECIFICATIONS

2.1 CURRENT:

- Charge: constant current, adjustable: 0 to 1.999A, in steps of 1mA (0.001A).
- Discharge: constant current, adjustable: 0 to 10.00A, in steps of 10mA (0.01A).

2.2 VOLTAGE:

- Charge: 0 to 40V.
- Discharge: 3 to 24V at full current, up to 48V at reduced current (240W max power dissipation).

2.3 MODES:

- CC - Constant Current Charge.
- CV - Constant Current Charge followed by Constant Voltage Charge.
- PEAK - Constant Current Charge and stop at Peak Voltage.
- ANALYSIS - Capacity Test Discharge.
- DISCH - Full discharge.

2.4 VOLTAGE CONTROL:

Adjustable: Usable from 00.0 to 40.0V on charge, and from 3.00 to 48.0V on discharge, with an accuracy of 1% \pm 1V.

2.5 METERS:

- Voltage: 3-1/2 digit, LED digital panel meter, 0 to 19.99 and 199.9V scales.
- Accuracy: \pm 0.25%, \pm 1 digit.
- Current: 3-1/2 digit, LED digital panel meter, 0 to 1.999A scale for charge and 0 to 19.99A scale for discharge.
- Accuracy: \pm 0.5%, \pm 1 digit.

2.6 STATUS INDICATORS:

- RUN (Green) - Output is on.
- CYCLE END (Green) - Pulsating (with beeper) to indicate end of a peak charge cycle or any timed cycle.
- PEAK VOLTAGE (Yellow) - The battery has charged to the programmed peak voltage.
- VOLTAGE FAULT (Red) - Reversed polarity or overvoltage.
- CAPACITY FAILURE (Yellow) - Low battery voltage on analysis.

2.7 CONTROLS:

Mode selector switch, RUN-RESET switch, voltmeter scale selector switch, timer speed switch and potentiometer to select the charge and discharge currents..

2.8 TIMER:

Internal, four digit readout with two digit selector and a speed control switch.

In the standard speed, the timer displays HH:MM and the hours are selected (HH).

In the fast speed, the timer displays MM:SS and the minutes are selected (MM).

In the test speed, the timer displays SS:TT, where TT is 1/60 of a second. The seconds are selected (SS).

2.9 FUSES:

- Input (line): 2A slow-blow (1A for 230V operation).
- Charge output, 3A Slow blow.
- Discharge output, 12A.

2.10 LINE VOLTAGE:

115/230VAC \pm 10%, 50-60Hz.

2.11 LINE CURRENT:

2A

2.12 AMBIENT:

+5°C to +35°C.

3.0 DESCRIPTION

The BCA-1210 is basically a precision voltage controlled current source/sink, with programmable current and voltage endpoints.

In the CC mode, the current is constant and it is set by the current selector potentiometer. The value of the current remains the same regardless of the battery voltage, from 0 volts (short circuit) up to a battery voltage of 40V. The charge current being also independent of the line voltage, within the specified line voltage limits.

In the CV mode, the current starts constant (as per the previous mode) and remains constant until the battery voltage is within a fraction of the selected value (0.5V approximately). At this point the current is automatically reduced and regulated to maintain the programmed battery voltage.

In the PEAK mode, the current starts constant (as in the first mode) but it is terminated automatically when the battery reaches the programmed peak voltage.

In the ANALYSIS mode, the current is constant and it is set by the current selector potentiometer. It is terminated automatically when the battery drops below the programmed voltage.

In the DISCHARGE mode, the current is constant. The current will gradually drop to zero when the battery reaches below 3V.

A monitor circuit provides the following safety features:

- a) REVERSE POLARITY: if the charger is connected in reverse to a battery (or single cell) having at least 0.5V of charge, the CHARGER-ANALYZER will signal a fault and inhibit further operation.
- b) OPEN CIRCUIT: if the charger is started without connecting it to a battery, or if the battery is open, or if the battery voltage rises abnormally (overvoltage), the CHARGER-ANALYZER will signal a fault and inhibit further operation.
- c) SHORT CIRCUIT: the CHARGER-ANALYZER is current limited, therefore, a short circuit will not result in any more current than the programmed level.

The integral digital timer provides time limits for the charge and discharge modes.



Figure 1 - Front Panel

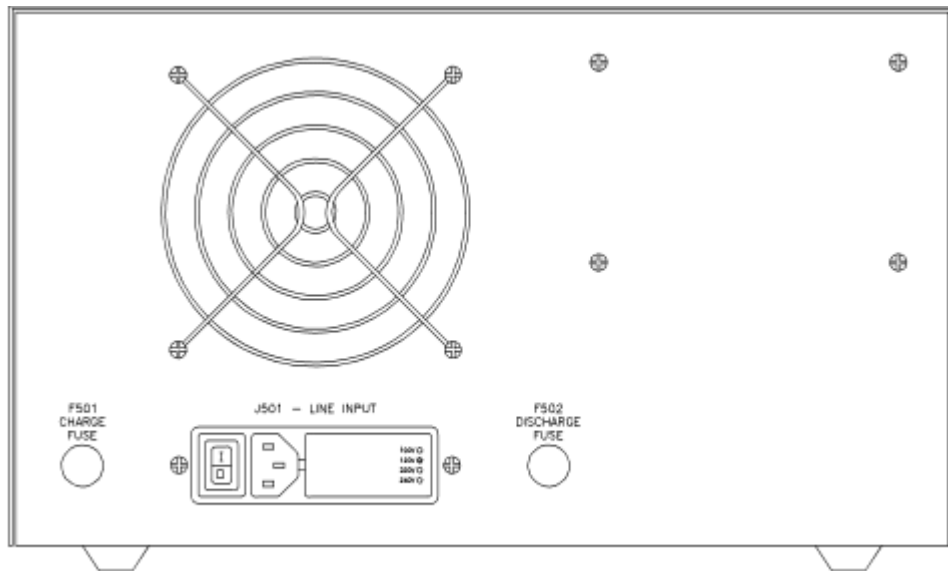

Figure 2 - Rear Panel

4.0 OPERATING INSTRUCTIONS

NOTE: before turning power ON or OFF, or before connecting or disconnecting a battery, make sure that the RUN-RESET switch is in the RESET position.

NOTE: reset before changing from charge to discharge or vice-versa.

4.1 CHARGE:

4.1.1 Mode:

- Select the required charge mode and turn the current selector to the required current (approximately 0.2A per turn).
- Check the battery manufacturer specifications and see section 4 (page 10) on charging recommendations.

4.1.2 Time:

- Select the time interval and the timer speed selector for required time interval in hours (HH:MM) or minutes (MM:SS).

4.1.3 Voltage:

- Set the voltage selector to the required float or peak voltage (format is XX.X) if in the CV or PEAK mode (not applicable to the CC mode). See BATTERY TESTING NOTES on section 5.0.

4.1.4 Connection:

- Connect the battery to the charger. Battery voltage will be displayed on the voltmeter. If the voltage is greater than 20V, set the voltmeter selector to 200V.

4.1.5 Run:

- Set the RUN-RESET switch to RUN. The ON (green) indicator will light up. The current will rise slowly.
- Adjust the current to the desired level.

4.1.6 Top:

- To stop the operation or to reset a FAULT condition, place the RUN-RESET switch in the RESET position.

4.2 DISCHARGE:

4.2.1 Mode:

- Select the required discharge mode and turn the current selector to the required current (approximate at 1A per turn).
- Check the battery manufacturer specifications.

4.2.2 Time:

- Select the time interval and the timer speed selector for the required time interval in hours (HH:MM) or minutes (MM:SS).

4.2.3 Voltage:

- Set the voltage selector to the required minimum voltage (format is XX.X) if in the ANALYSIS mode (not applicable to the FULL discharge mode).

4.2.4 Connection:

- Connect the battery to the charger. Battery voltage will be displayed on the voltmeter. If the voltage is greater than 20V, set the voltmeter selector to 200V.

4.2.5 Run:

- Set the RUN-RESET switch to RUN. The ON (green) indicator will light up. The current will rise slowly.
- Adjust the current to the desired level.

4.2.6 Stop:

- To stop the operation or to reset a FAULT or CAPACITY FAILURE condition, place the RUN-RESET switch in the RESET position.

5.0 BATTERY TESTING NOTES

The Charge & Float and the Charge & Peak Stop modes are particularly useful with lead acid batteries, where the battery voltage is a better indicator of the state of charge, as compared with Nickel-Cadmium batteries where terminal voltage gives little information on the state of charge.

Lead-Acid batteries are normally float charged (constant voltage) typically at 2.3V/cell. A 6 cell pack (12V) will then be float charged with the voltage selector at 13.8V. In this mode, the charge current is set to the highest level that the cells will safely take (typically up to 1C depending on the battery type and specific manufacturers instructions). This will be the charge current until the float voltage is reached, at which time the current will diminish to the level needed to maintain the float voltage.

Lead-Acid batteries can also be charged in a manner in which it is possible to know much better the end of charge. When a Lead-Acid cell is charged with constant current at C/15 to C/10, the end voltage will rise rapidly at about 90 to 95% of charge, which occurs at about 2.4 to 2.45V/cell. A 5A-hr, 6 cell pack, can be charged at 335mA to 500mA, with the voltage selector at 14.7V. The CHARGER-ANALYZER will stop the charge operation when the rapid rise of end-of-charge voltage is detected.

For Nickel-Cadmium batteries, the most effective charge method is constant current vs time. In the absence of any particular instructions from the manufacturer, charging at c/10 for 12 to 16 hours will insure a complete charge.

The Nickel-Cadmium batteries can also be charged in the float mode, with a voltage of 1.4 V/cell (a 20 cell battery would be set to 28.0V).

NOTE: Prolonged use of the float (constant voltage) method on Nickel-Cadmium batteries will result in cell imbalance, which could eventually lead to premature cell failure due to un-even charge acceptance and un-even discharge capacity.

6.0 VERIFICATION OF PERFORMANCE AND CALIBRATION

The following steps will provide information necessary to establish if the BCA-1210 is performing within established specifications.

6.1 METERS BOARD

6.1.1 VOLTMETER:

- Set the meter voltage selector to 20V.
- The Voltmeter must read zero. (The polarity sign may flicker between positive and negative).
- *NOTE: Zero on the voltmeter is not adjustable.*
- Connect to an external voltage source and measure with a voltmeter of established accuracy. Set the voltage between 15 and 19V.
- Readings in the voltmeter of the CHARGER-ANALYZER must be within $\pm.25\% \pm 1$ digit.
- Adjust R17 as necessary to match the reading on the CHARGER-ANALYZER to the reference voltmeter.
- b) Set the meter voltage scale selector to 200V.
- Apply a voltage of at least 50V.
- Readings must be within $\pm.35\% \pm 1$ digit.
- *NOTE: The 200V scale is derived from a divider network, no adjustment is available.*

6.1.2 AMMETER:

- Verify that the ammeter reads zero with no current being passed by the CHARGER-ANALYZER.
- Connect an ammeter of established accuracy in series with the output leads of the charger.
- Set the CHARGER-ANALYZER for Constant Current Charge and adjust the current for 1900mA.
- Verify that the current readings are within $\pm 0.5\% \pm 1$ digit.
- Adjust R10 as necessary to match the reading on the CHARGER-ANALYZER to the reference ammeter.
- *Note: there are no separate adjustments for charge and discharge. If there is a disagreement between the charge and discharge modes the individual shunts must be verified.*

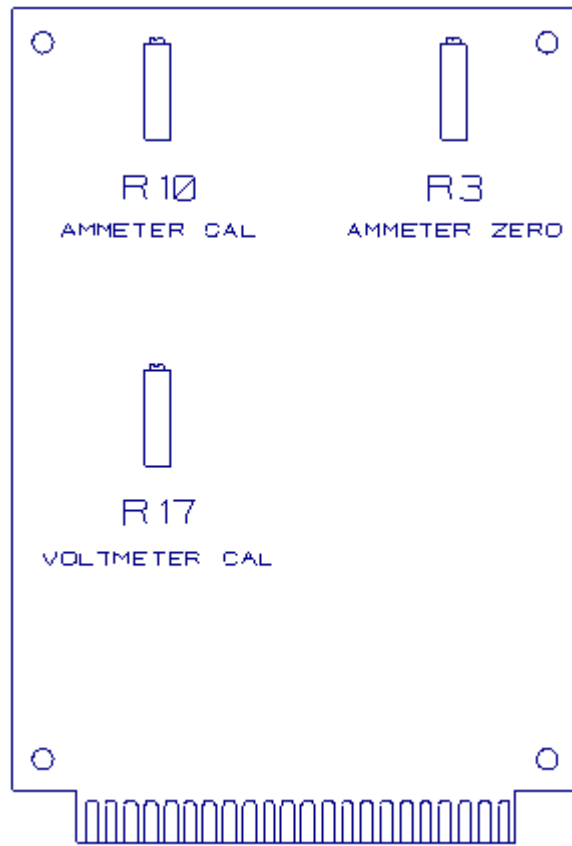

Figure 3 - Meters Board Adjustments

6.2 CONTROL CIRCUIT BOARD

6.2.1 R30 and R16, ZERO:

- Turn power on and keep the CHARGER-ANALYZER in Reset.
- Adjust R30 for $0V \pm 0.005V$ at U11 pin 1 (or bottom of C19). Adjust R16 for $0V \pm 0.005V$ at U11 pin 7 (or left of C18). Use the negative side of C9 as a common point.

6.2.2 R31, MAX CURRENT:

- Connect the CHARGER-ANALYZER to a 10 to 20 cell battery using an external ammeter with an accuracy of 0.5% or better.
- Set the charge current selector potentiometer to maximum and adjust R31 for a current of 1.999A .

6.2.3 R44, VOLTAGE:

PEAK CHARGE and ANALYSIS (Capacity Test)

- Connect a power supply capable of producing at least 21V (very little current required) to the output leads of the CHARGER-ANALYZER. Connect also a reference voltmeter to the output of the Power Supply.
- Set the mode selector to PEAK charge. Set the current selector potentiometer to zero and set the voltage selector to 20.0 (200).
- Set the power supply to 19V, turn it on and start the CHARGER-ANALYZER.
- Advance the power supply output towards 20V and adjust R44 so that the CHARGER-ANALYZER responds by stopping on the peak voltage.
- Reset the CHARGER-ANALYZER and set the mode selector to Auto Discharge.
- Set the power supply to 21V and start the CHARGER-ANALYZER.
- Reduce the output of the power supply towards 20V and note the voltage at which the CHARGER-ANALYZER indicates capacity failure. (no separate adjustment available here).

FLOAT (Constant Voltage) CHARGE VERIFICATION

- Disconnect power (and any output connections) from the CHARGER-ANALYZER.
- Remove the small red wire from position 8 in the terminal block and connect it to the positive terminal of a power supply capable of producing at least 20V (very low current needed). Connect the negative terminal to the black output lead of the CHARGER-ANALYZER. Connect also a reference voltmeter to the output of the power supply.
- Set the mode selector to Charge and Float, set the current selector to maximum, set the power supply to 19V and connect the CHARGER-ANALYZER to a battery (any).
- Start the BCA-1210 and advance the power supply voltage towards 20V. The charge current will start at maximum and will begin to diminish when the power supply voltage approaches 20.0V Reset.

- Disconnect power and battery connections and return the small red wire to position 8 in the terminal block.
- *Note that there is no separate adjustment for this mode as it depends on the calibration previously performed for Peak charge and Capacity Test.*

ALTERNATE VERIFICATION

- Set the mode selector to FLOAT CHARGE.
- Set the current selector to zero.
- Connect a partially charged battery to the Charger-Analyzer and note the voltage registered in the Voltmeter.
- Set the voltage selector to a voltage above the battery voltage (about one volt).
- Start the Charger-Analyzer, advance the current the current and note the registered battery voltage.
- The charge current will be able to be increased until the battery voltage approaches the programmed voltage. AT that point the current will be automatically limited by the control circuit to maintain the programmed voltage.
- *Note that there is no separate adjustment for this mode as it depends on the calibration previously performed for Peak charge and Capacity Test.*

6.2.4 TIMER:

- Set the speed selector to test and the set the time selector to 00.
- Set the function selector to CC and set the current selector to zero (no current).
- Start the BCA-1210. It will immediately go to cycle end. Reset
- Set the time selector to 01 and start the Charger-Analyzer. It will cycle end after one second. Reset.
- Repeat for 02, 04, 08, 10, 20, 40 and 79.
- *Note: the timer is microprocessor controlled; no adjustments are required.*
- Test also that in the hours mode the timer advances at the rate of one count per minute and that in the minutes mode, the timer advances at the rate of one count per second.
- *Note: the colon flashes at the rate of one pulse per second regardless of the timer speed selected.*
- Set the timer speed to minutes and seconds and start the charger. Note the reading in the timer window and turn power off. The colon will remain on to indicate that the timer is powered by the back-up battery.
- Turn power back on and note the time at which the timer starts.
- The timer must resume at the same time displayed when power was turned off.
- If the time interval is not kept, check/replace the backup battery (7 cell or 8 cell Nickel-Cadmium).

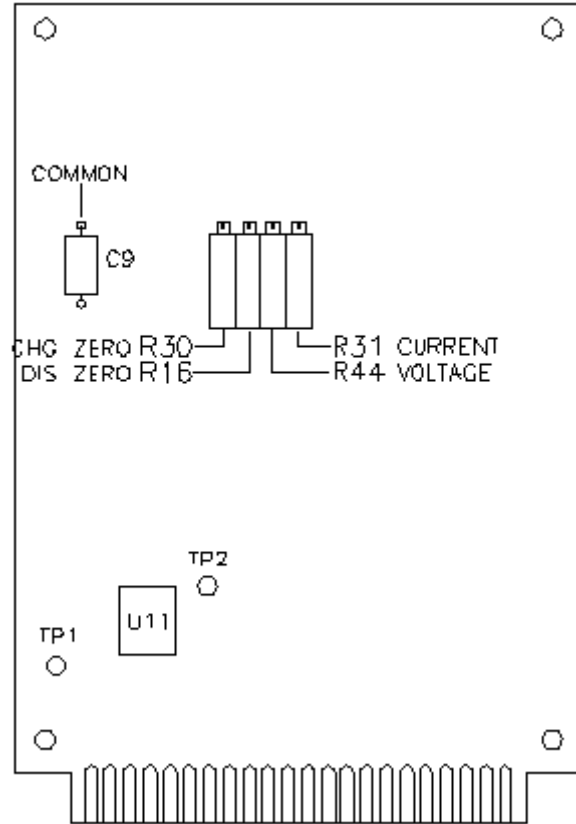

Figure 4 - Control Board Adjustments

6.2.5 CHARGE and DISCHARGE CURRENT:

- Connect the BCA-1210 to a 20 cell battery.
- Set the current selector for about 1.000A charge.
- Test for charge and discharge and note the current readings. Maintaining the same current selector settings, re-test by connecting the BCA-1210 to a lower number of cells (ie: 5 and 10). Verify that the current remains constant.

7.0 TROUBLESHOOTING

7.1 DOES NOT TURN ON:

- Unit not plugged in.
- Open line fuse.

7.2 DOES NOT CHARGE or DISCHARGE:

- Open output fuse.

7.3 DOES NOT CHARGE IN THE CONSTANT VOLTAGE MODE:

- The Battery voltage is above or very close to the voltage selected.

7.4 GOES INTO CYCLE END IMMEDIATELY IN THE PEAK CHARGE MODE:

- Battery voltage above or very close to voltage selected (the peak indicator will be on).

7.5 FAULT ALARM:

- Open output fuse.
- Battery not connected or open.
- Reverse polarity connection.
- Worn out or dry battery (voltage rising rapidly)
- Resistors and/or diodes in the charge path (Battery packs may not be accessible directly from outside connectors due to diodes or resistors placed by the manufacturer to protect the battery and/or circuits. It is imperative then that the instrument where the battery pack is housed be disassembled to reach the battery terminals and also the individual cells).

7.6 CAPACITY FAILURE ALARM:

- Battery below setting on voltage selector. Battery not connected or open.

7.7 GOES INTO CYCLE END IMMEDIATELY IN ANY MODE:

- Time selector set to 00.

7.8 DOES NOT RESPOND TO A CHANGE IN THE TIME SELECTOR:

- Time selector value is read at the start of a run.
- To make effective a change of time the charger must be reset and re-started.

8.0 INSTALLATION

8.1 SPACE:

- Place the BCA-1210 so that heat can be adequately dissipated through the rear panel, particularly during discharge.
- Operation of the unit in a confined space without proper ventilation can lead to premature semiconductor damage due to the heat build-up.
- *NOTE: use of a small fan to circulate the hot air that may accumulate around the unit will greatly prolong the life of the instrument and improve its performance.*

8.2 LINE VOLTAGE:

Operate the BCA-1210 from an AC source of 115VAC (or 230VAC), $\pm 10\%$, 50-60Hz.

Line voltage change:

- To convert the BCA-1210 from the standard 115V to 230V operation, remove the line cord and the cover to the power entry block (rear of the panel). Remove the small card and re-position so that the plastic tip protrudes through the 240V opening on the cover.
- See fig 2 on page 7 for a pictorial of the Rear Panel.
- Change the fuse to a 1A SB.
- *Note: fuses can be US standard (one) or European miniature (two).*

9.0 WIRING DIAGRAM

10.0 REVISION INDEX

REVISION	DATE	NOTES
1.0	28 September 1994	Release
1.1	28 November 1994	Text Corrections
2.0	29 September 2005	Format and text updates